

format

A Levitated-Pole Superconducting Dipole for Use in the Beam Separators of LHC

Peter McIntyre and Akhdiyov Sattarov

Abstract—A design is presented for a superconducting levitated-pole dipole for applications requiring operation in high heat load and/or radiation damage to the superconducting coil. The application that motivated the design is the first dipole D1 that coalesces and separates the proton beams in the insertion region for the Large Hadron Collider (LHC). The superconducting coils are supported on cold-iron pole pieces that are ‘levitated’ within a warm-iron flux return by balancing the force between coils against the image force across an insulating gap in the steel flux return. It is possible in this design to provide a 9 Tesla dipole field with no heat intercept in the mid-plane, so that the heat and radiation from secondary particles do no harm.

Index Terms—superconducting dipole, heat transfer, radiation damage

I. INTRODUCTION

EACH high-luminosity intersection region (IR) in the Large Hadron Collider LHC poses three significant challenges for the match of the physics mission of the collider with the optical train of the arcs: focal optics, crossing and separation of the two beams, and management of heat and radiation from secondary particles that are produced in proton-proton interactions and then lost into the cold mass of the magnets. The focal optics is optimized by placing the quadrupole triplet as close as possible to the interaction point (IP). This minimizes β_{max} and also minimizes the sensitivity to chromaticity and to alignment errors and error multipoles in the IR magnets. Preliminary discussions with both experimental teams indicate that the first quad could be placed at a distance $s \sim 12$ m from the IP.

The beams must be crossed at small angle and then separated, and the separation dipole must be placed as close to the IP as possible to minimize the number N_s of subsidiary bunch-bunch crossings that make long-range beam-beam interactions.

The proton-proton interactions at the IP produce an intense flux of particles in the forward directions. Many of those particles strike the first quad Q_1 and the separation dipole D_1 .

Manuscript received September 20, 2005. This work was supported in part by the U.S. Department of Energy under Grant DE-FG03-95ER40924 and by EC FP6, CARE-RII3-CT-3003-506395.

P. McIntyre and A. Sattarov are with the Dept. of Physics, Texas A&M University, College Station, TX 77843 (corresponding author is P. McIntyre (979-845-6015; fax 979-845-2590; e-mail: p-mcintyre@physics.tamu.edu).

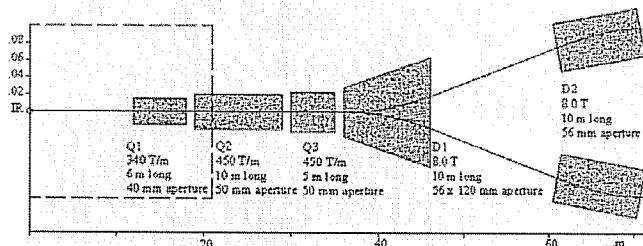

Figure 1. Placement of optical elements in an IR optimized for high-luminosity at LHC.

Table 1. Main parameters of the elements in the optimized IR

magnet	structure	field/ gradient	Length (m)	aperture (mm)
Q_1	Ironless, round cable	340 T/m	6.5	40
Q_2	Block-coil, iron return, Rutherford cable	450 T/m	10	50
Q_3	Rutherford cable	450 T/m	5	50
D_1	Levitated-pole dipole	9 T	10	56 x 120

Table format

Indeed the most energetic particles travel down the beam tube and are swept into the side walls of D_1 by its dipole field. The resulting heat load is estimated at ~ 3 kW for the design luminosity [1]. Designs have been suggested for dipoles with no superconductor in the midplane [2], but the best solution for such an extreme radiation and heat environment would be to remove all cryogenic structures from the midplane.

We are investigating an optimization of IR design [3] in which the optical elements are located as close as possible to the IP, as shown in Figure 1. The above criteria have led us to particular choices for the technology of each of the magnetic elements, as summarized in **Error! Reference source not found.** The purpose of this paper is to present the design for a levitated-pole dipole that could provide the required performance for D_1 . A companion paper [4] describes a structured-coil quadrupole for Q_1 .

II. THE LEVITATED-POLE DIPOLE

We propose a somewhat different design in which the cold-iron poles of the dipole are supported within a warm-iron flux return across a gap, as shown in Figure 2. The coil geometry and the separation gap can be designed such that the total Lor-

Why 2 pages only? interesting idea but not enough information!

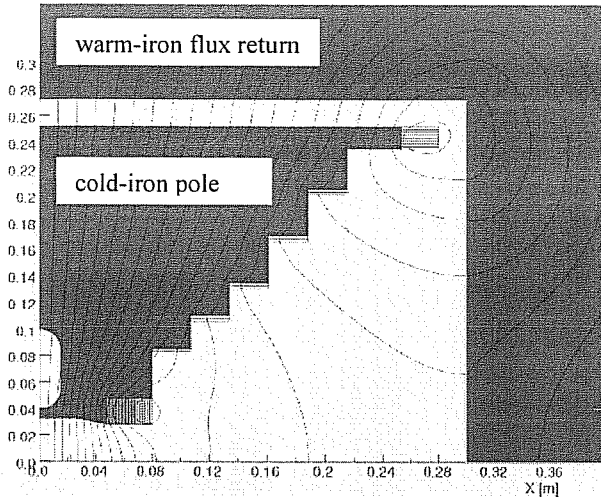

Figure 2. Levitated-pole dipole: 9 Tesla, 56 mm aperture.

entz force on the assembly of the cold-iron pole piece and the coils is zero – we call this a levitated-pole dipole. The concept was first utilized by T. Kawaguchi *et al.* [5] in the design of the sector magnets for a ring cyclotron. In this approach the radiation and heat from particles is deposited in room-temperature steel.

The magnetic field strength is limited by the requirement that the steel be unsaturated at the gap between pole tip and flux return. The design shown in Figure 2 corresponds to a central field of 9.0 Tesla. The pole is tapered at a ~45° angle to reduce the field in the pole steel from ~9 T at the pole tip to ~1.5 T at the gap.

The design shown has been optimized for field quality; $b_3 \sim 10^{-4} \text{cm}^{-2}$ over the dynamic range require for LHC operation. Only the winding assembly just above the beam tube needs to be made using Nb₃Sn superconductor. All of the windings along the staircase of the pole are be made of NbTi.

Because the magnetic forces on the cold pole assembly cancel, it can be supported using low-heat-load tension supports, so the overall cryogenic load should be modest.

Figure 3 shows the calculated forces on the superconducting coil and on the cold iron, as a function of field strength. Positive force corresponds to repulsion between the two pole tips. The maximum repulsive force occurs at a field of ~6.5 T, and has a total of ~200 kN/m. The force actually reverses at low field (<3T), but the forces are quite modest there.

how about above 3T, looks like a strong attraction

III. ASSEMBLY AND SUPPORT

Figure 4 shows a conceptual design for the assembly and support of the levitated dipole. The two poles are tied to one another by (6 cm)² stainless steel struts, located on each side of the poles, connecting to the outermost facet of each pole. Placing these struts every 75 cm along the length of the dipole should suffice to rigidly connect the two poles and support them under the forces of Figure 3 with maximum deflection of < 0.5 mm. Since such deflection during ramp of the magnet is slow and distributed over a 75 cm period, it should pose little risk of quenching the coil. The gravitational load and stabili-

slow deflections?, 500µm of deflection?

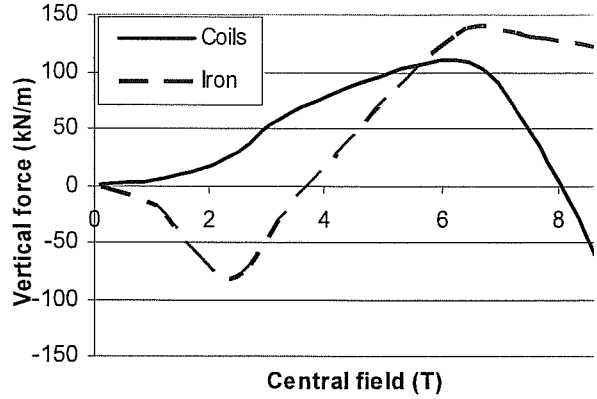

Figure 3. Forces on coil and cold iron as a function of field.

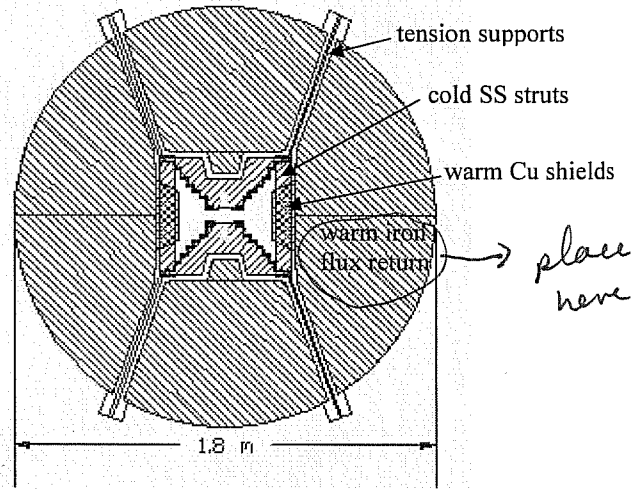

Figure 4. Assembly of levitated-pole dipole showing support of pole structure within flux return.

zation of the unstable equilibrium in the horizontal direction are supported by tension supports extending through the warm-iron flux return. The width of the dipole field region must increase along the length of the D1 as the beams separate; the pole width can be tapered as necessary.

Lastly the cold struts connecting the two poles are at cryogenic temperature and span the midplane, so they would intercept some of the secondary particles swept to the sides. Non-magnetic absorbers can be attached to the warm-iron flux return as shown, filling much of the gaps between struts and shadowing the cold struts from receiving heat load.

REFERENCES

[1] N.V. Mokhov *et al.*, LHC Project Report 633 (2003).
 [2] R. Gupta *et al.*, 'Open midplane dipole design for LHC IR upgrade', *Proc. MT-18*, Morioka, Japan (2003).
 [3] A. Sattarov and J.-P. Koutchouk, and P. McIntyre, "Towards an optimization of the LHC intersection region using new magnet technology", *Proc. Particle Accel. Conf.*, Knoxville, TE, May 16-20, 2005.
 [4] P. McIntyre and A. Sattarov, "Structured-cable superconducting quadrupole for high-heat-load applications", this proceedings.

[5] T. Kawaguchi *et al.*, "Design of the sector magnets for the Riken superconducting Ring Cyclotron", *Proc. 15th Conf. on Cyclotrons*, Caen, 14-19 June 1998.