

A test facility for fast-ramped superconducting magnets for FAIR

Gertrud Walter, Claus Schroeder, Günther Heß, Franz Klos, Stefan Berlinghof, Pierre Schnizer, Eric Floch, Marion Kauschke, and Gebhard Moritz

Abstract— For testing fast-ramped superconducting magnets for the FAIR project (Facility for Antiprotons and Ion Research) a test facility is set up at GSI to test model and prototype superconducting magnets for the different planned machines (SIS100, SIS300, SFRS and the storage rings). The following magnet tests are planned: measurements of losses, quenches and training, magnetic measurements, temperature distributions in the magnet, and long-term stability tests. The facility accommodates forced-flow cooled model dipoles (Nuclotron-, RHIC-, and UNK-type) with a max. length of 1.4 m, prototype magnets (dipoles, quadrupoles, corrector magnets) with a maximum length of 2.6 m, and bath-cooled magnets for the planned CR, SFRS, and NESR/RESR.

Index Terms—Accelerator magnets, test facilities, loss measurement magnetic field measurement.

I. INTRODUCTION

To realize the FAIR project [1] different research and development programs for superconducting accelerator magnets are in progress. The planned accelerator facility consists mainly of two synchrotrons (SIS100 and SIS300), a variety of storage rings with different demands, and the corresponding high energy beam transport lines. A basic requirement is the development of fast-ramped superconducting magnets as they will be used for the SIS100 ($B_{\max}=2$ T, $dB/dt_{\max}=4$ T/s) and for the SIS300 ($B_{\max}=6$ T, $dB/dt_{\max}=1$ T/s), among others. As the R&D programs are carried out in international collaborations, model magnets for the different machines are built and tested in different laboratories and together with in-

gether with industry. To save time and money, all magnets which are considered rely on existing magnet designs, such as the Nuclotron design for SIS100 and the UNK design for SIS300 [2]. In both cases the main objectives of the magnet R&D are the improvement of field quality and the reduction of dynamic losses in the fast-ramped operation mode. To confirm the experimental results of our collaborators and to gain experience with the handling of superconducting accelerator magnets, we decided to build a test facility for all kinds of superconducting magnets considered for FAIR:

- 1) Forced-flow two-phase helium cooled window-frame magnets for SIS100, 1.4 m long model magnets and 2.6 m long full-length prototypes
- 2) Forced-flow single-phase helium cooled $\cos(n\theta)$ -type magnets for SIS300, 1 m long model magnets and 2.6 m long full-length prototypes
- 3) Helium bath-cooled superferric, i.e. iron-dominated superconducting magnets for the storage rings CR, NESR/RESR and for the SFRS

II. MAIN COMPONENTS OF THE TEST FACILITY

A. General layout

The test facility consists of a refrigerator, two feedboxes, an all-purpose cryostat, a power supply, and a quench detection system.

B. Refrigerator

To provide helium for the magnet cooling we use a refrigerator of type TCF 50 from Linde Kryotechnik with a refrigeration power of about 400 W. The plant was used at CERN as a liquefier and some modifications had to be done by the Linde Company to fit to our requirements. Besides the replacement of one of the heat exchangers and of a helium sump in the cold box, a new distribution box was added to the plant containing an ejector and a liquid helium pump. The pump provides a single-phase helium mass flow of up to 150 g/s. The ejector will provide a further temperature reduction, expected to 3.8 K.

C. Feedbox

To supply the forced-flow cooled magnets with helium and with electrical current, two identical feedboxes were constructed. Besides one pair of standard current leads (optimized for 6500 A, working up to 11000 A), each feedbox contains temperature and pressure sensors, as well as the required cold valves. Two Coriolis mass flowmeters are also integrated in

Manuscript received September 18, 2005.

Gertrud Walter is with the GSI, 64291 Darmstadt, Germany (corresponding author to provide phone: ++49-6151-71-2061; fax: ++49-6151-71-2043; e-mail: g.walter@gsi.de).

Claus Schroeder is with the GSI, 64291 Darmstadt, Germany (e-mail: c.schroeder@gsi.de).

Günther Heß is with the GSI, 64291 Darmstadt, Germany (e-mail: g.hess@gsi.de).

Franz Klos is with the GSI, 64291 Darmstadt, Germany (e-mail: f.klos@gsi.de).

Stefan Berlinghof is with the GSI, 64291 Darmstadt, Germany (e-mail: s.berlinghof@gsi.de).

Pierre Schnizer is with the GSI, 64291 Darmstadt, Germany (e-mail: p.schnizer@gsi.de).

Eric Floch is with the GSI, 64291 Darmstadt, Germany (e-mail: e.floch@gsi.de).

Marion Kauschke is with the GSI, 64291 Darmstadt, Germany (e-mail: m.kauschke@gsi.de).

Gebhard Moritz is with the GSI, 64291 Darmstadt, Germany (e-mail: g.moritz@gsi.de).

each box, as appropriate for the different mass flow regimes of single- (10-150 g/s) and two-phase helium (2-10 g/s). A flow scheme of the feedbox is shown in Fig. 1.

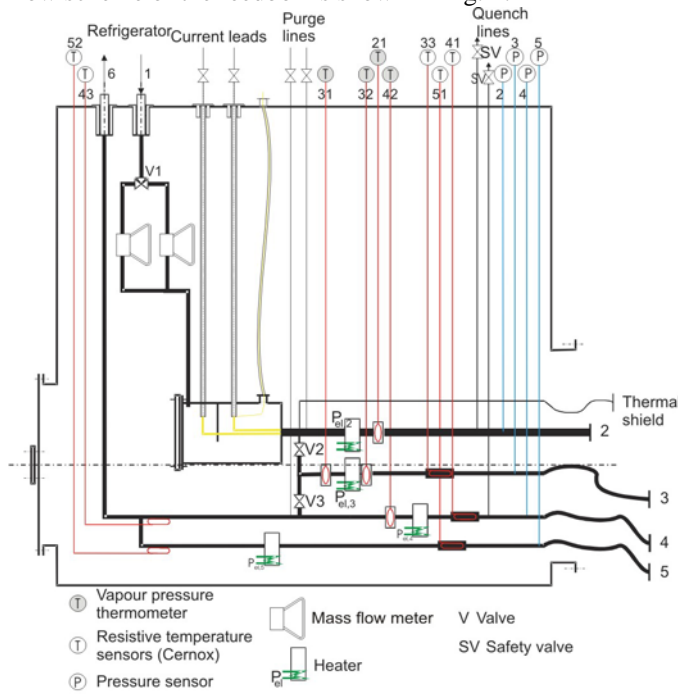

Fig. 1. Flow scheme of the feedbox.

Each feedbox is equipped with two separate helium inlet (2 and 3), and two return lines (4 and 5). It allows the separate helium supply for coil and yoke of a magnet. Different sensors for temperature, pressure and helium flow are installed to allow loss measurements as described in the next section. To measure the helium temperature, resistive temperature sensors were placed within the helium flow in lines 3 to 5. Cernox™ sensors were chosen to minimize any influence of magnetic stray fields on the temperature measurement.

D. Cryostat

As the test facility will be used for testing a variety of different superconducting model and prototype magnets, we decided the construction of a rectangular-shaped all-purpose cryostat as shown in Fig. 2. The length of the cryostat is about 4 m and is equipped with large-scale rectangular flanges. It is easy to handle: the installation of a magnet can be prepared outside, and the cold mass can be transferred into the cryostat simply by using a crane. Different CF-flanges give us high flexibility to mount further measuring equipment or sensors to the cold mass.

E. Power Supply and Quench Protection

The fast-ramped superconducting magnets will be operated using an AC power supply with an integrated water-cooled dump resistor. The parameters of the power supply are as follows:

- Operation: AC and DC
- Current: 500 to 11000 A
- Max. ramp rate: 18000 A/s

- Max. Voltage: 90 V
- Current stability (rel.): $2.5 \cdot 10^{-4}$ (for ramp and flat top)
- Dump resistor: 72 mΩ

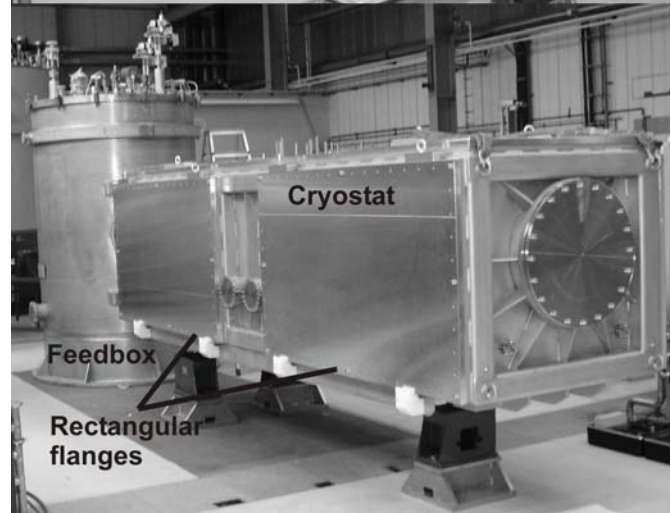
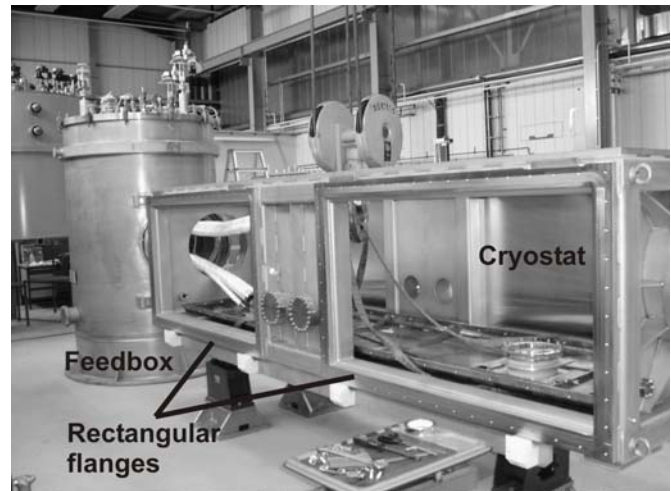

Fig. 2. Rectangular shaped all-purpose cryostat.

F. Quench Detection System

To ensure a safe operation of all magnets of interest, a quench detection system is installed. To eliminate the inductive voltage due to the fast current variations and find the resistive voltage induced by a quench, bridges are used. They compare two equivalent coil parts (i. e. upper and lower coil in a dipole). The electronics are adapted from the series test facility of the LHC-dipole magnets at CERN. The system consists of

- POTAIM chassis, where bridges are located. Once the resistive voltage has exceeded its threshold (0,1 or 0,2 V), then a trigger signal is sent to the security matrix.
- Security Matrix to control the peripherals (power supply, quench heater, etc.) i.e. all necessary 'actions' immediately after a quench.
- Data acquisition system (low- and high frequency) to record the voltage tap signals as a function of time, and all trigger signals from the security matrix.

The quench detection software AQA [3] is also adapted from CERN.

III. MAGNET TESTING

The magnet testing program includes electrical and thermodynamic loss measurements, measurements of the quench and training behavior of magnets, and void fraction measurements (in case of two-phase cooling) – besides magnetic measurements which are described separately in section IV.

A. Loss measurements

Following the flow scheme in Fig. 1, in case of single-phase helium cooling of the $\cos\theta$ -magnets, one can deduce the integral loss \dot{Q} of the magnet, assuming one helium flow through the magnet, i.e. coil and yoke are thermally in series:

$$\begin{aligned} \dot{m}_2 &= \dot{m}_1 - \dot{m}_{cl} + \dot{m}_{sh} \\ \dot{Q} &= \dot{m}_2 \cdot (-h(p_2, T_{21}) + h(p_4, T_{41})) \end{aligned} \quad (1)$$

The measured quantities p_2, p_4 are the pressures and T_{21}, T_{41} are the temperatures at helium supply No. 2 and 4, respectively. The associated enthalpies $h(p, T)$ are tabulated, see e.g.[4]. The mass flow \dot{m}_1 is measured using the Coriolis mass flow-meter, \dot{m}_{sh} is the mass flow of the cooling shield and \dot{m}_{cl} is that of the current leads, adjusted by the associated valves.

In case of a two-phase cooled superferric magnet \dot{Q} is determined by

$$\begin{aligned} \dot{m}_2 &= \dot{m}_1 - \dot{m}_{cl} - \dot{m}_{sh} \\ h_{41} &= -\frac{P_{el,4}}{\dot{m}_2} + h(p_2, T_{21}) \\ \dot{Q} &= \dot{m}_2 \cdot (h_{41} - h(p_2, T_{21})) \end{aligned} \quad (2)$$

as long as coil and yoke are cooled in series. In this case $P_{el,4}$ is the electrical power of the heater which is installed in the supply line no. 4.

As already mentioned in section II.C, coil and yoke can be connected in parallel, and also all different combinations of single- and two-phase helium cooling are possible. Then similar sets of equations can be derived [5].

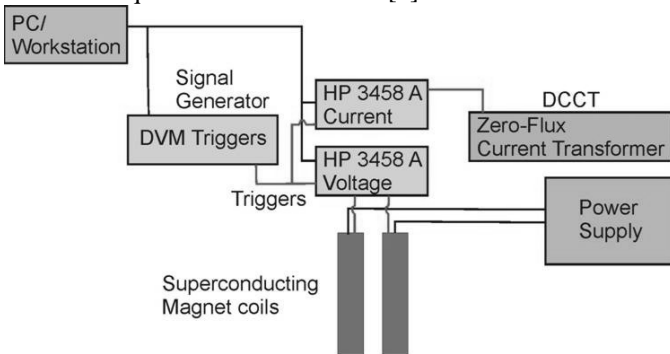

Fig. 3: Current and voltage measurements using high accuracy digital multimeters (HP 3458 A).

For redundancy we can also determine the integral loss by means of an electrical current-voltage-measurement of

$$\dot{Q} = V \cdot I \quad (3)$$

The schematic setup is shown in Fig. 3.

B. Quenches and training

To analyze the training behavior and to measure quench propagation velocities, voltage taps can be soldered to the magnet coil at different positions. The voltage taps are connected to the POTAIM cards described in section II.F.

C. Void fraction measurements

In case of two-phase cooling it is of interest to measure the void fraction of the helium flow at inlet and outlet of the magnet. For that reason we will install a radio frequency void fraction sensor developed and manufactured at the JINR in Dubna [6]. The measurement is based on the dependence of the dielectric permittivity of helium on the void fraction, i.e. the relative amount of gaseous to liquid helium. The details of the principle are described elsewhere [7,8]. The sensor is equipped with flanges and can therefore be connected at different positions, i.e. at the magnet's helium inlet pipe, at the outlet pipe, or between coil and yoke.

IV. MAGNETIC MEASUREMENT

A main task of the test facility is the characterization of the magnet field quality by magnetic measurements. Our planned measuring concept is that the magnet is operated at cryogenic temperatures (4 K) while the measuring equipment is working at room temperature. For that purpose we developed an anti-cryostat made from non-conducting materials (see section A) to avoid additional AC losses during the ramping of the magnets.

To characterize the magnets' field quality we intend to measure: the field direction and the field homogeneity, the integral of the magnetic field $\int Bdl$ for dipoles (with B the magnetic field and l the length of the magnet), the integral gradient $\int Gdl$ (with G the magnetic field gradient) for quadrupoles; furthermore the axis of quadrupoles and higher order multipoles. However, in case of fast-ramping also the time dependence of the multipoles should be measured.

For the magnetic measurements we develop a so-called 'mole' which is described below in section B.

A. Anticryostat

We developed an anti-cryostat made from non-conducting materials to avoid additional AC losses during the ramping of the magnets. It consists of two tubes fabricated of fiber glass epoxy (G10), with vacuum and superinsulation in-between for thermal isolation. Its' ends are moveable, so it can be placed in any arbitrary lateral location inside the rectangular frame of window- frame magnets (e.g. SIS 100 magnets). The temperature of the inner tube is controlled by copper heaters.

B. Mole

Many of the magnets of interest are operated in a pulsed mode, and therefore their field quality has to be measured in

pulsed as well as in the continuous operation mode. A measurement approach based on rotating coils was selected, as they allow to measure more than one point along the magnet axis on the one hand, but on the other hand the measurements

are fast enough as the signal is integrated over their length [8].

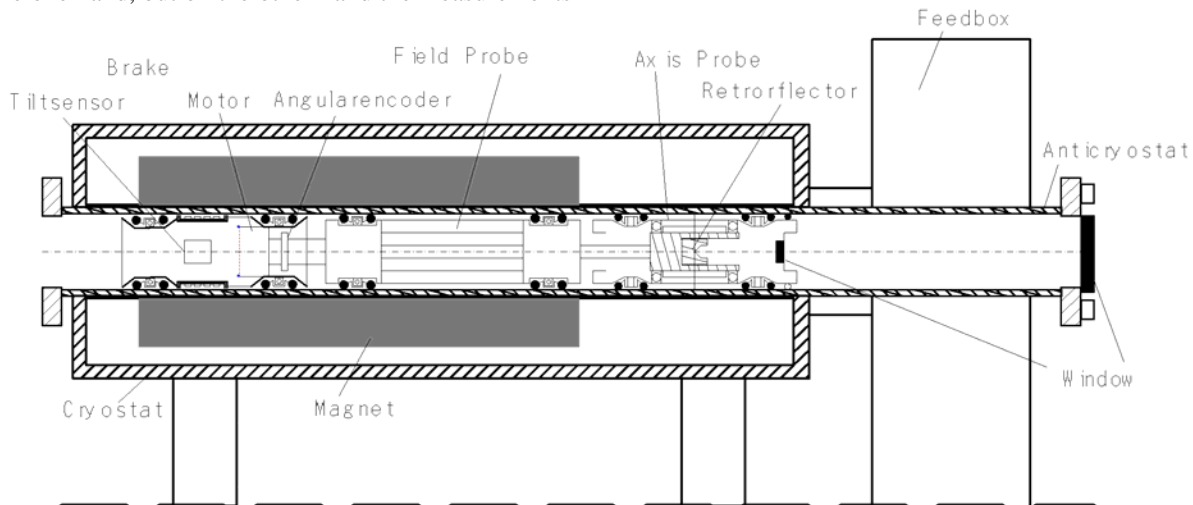

Fig. 4: Sketch of the test stand and the magnetic measurement system (not to scale).

Magnetic measurement systems having their whole auxiliary equipment (motor, angular encoder, etc) inside the magnetic field are often called “moles”. They can be considered as the solution of choice if the length of the magnet is much larger than the aperture. Even if the magnets of interest are of moderate length (< 3 meters), the different apertures and the total measurement lengths (due to the feedbox and cryostat size) justify this solution (see Fig. 4). The mole is split into the driving unit, the field probe, and the axis probe. The steady-state field of the magnets is measured using the field probe as a rotating coil. The signal is then integrated and the field information is obtained by a Fast Fourier Transformation and an appropriate scaling taking into account the geometry of the probe [10]. For the pulsed measurements the field probe is used as a stationary coil. The signal is measured during one pulse, then the coil is turned by a certain angle and the pulsed measurement is repeated until the whole turn is finished. The data are recorded and the magnetic field is reconstructed as a function of the current.

The magnetic axis of the quadrupoles and higher order harmonics are measured using a rotating coil. A retro-reflector is mounted on its centre to allow the measurement of its position using a laser tracker.

Combining these two measurements, the position of the magnet can be given with respect to the cryostat, and therefore also studies of cool-down effects are possible. As the inner tube of the anticyostat is heated, it must be evacuated to avoid deflection of the laser light [11]. For that purpose a sealed glass window is mounted on one end of the anticyostat, while the axis coils housing seals the other end with a gasket.

Fiducials are fixed on the flange supporting the glass window to measure and correct the tilt of the glass window with respect to the axis of the laser light.

As the air pressure from outside generates a force of 170

N on the mole, a special dumper at the rear end of the anticyostat will stop the mole and thus prevent subsequent damage of surrounding equipment, if the longitudinal displacement mechanisms breaks.

V. OUTLOOK

The prototype test facility is in the commissioning phase. We intend to measure a first model magnet of SIS100-type by the end of this year.

REFERENCES

- [1] W. F. Henning, "FAIR- An International Accelerator Facility for Research with Ions and Antiprotons", *Proceedings of the European Particle Accelerator Conference (EPAC 2004)*, July 5-9, 2004, Lucerne, Switzerland, pp. 50-53
- [2] G. Moritz, "Fast-pulsed Superconducting Magnets", *Proceedings of the European Particle Accelerator Conference (EPAC 2004)*, July 5-9, 2004, Lucerne, Switzerland, pp. 132-136
- [3] AQA, 'Automatic Quench Analysis', <http://m.home.cern.ch/m/mtauser/www/archives/events/review2/khomenko.pdf>
- [4] NIST Technical Note 1334, 1998
- [5] M. Kauschke, B. Lust, Internal note "Anschlußmöglichkeiten der Feedboxen", Internal Note 2003
- [6] Yu.P.Filippov, A.I.Alexeyev, A.V.Ivanov and B.V.Lunkin. "Expanding application of cryogenic void fraction sensors". *Cryogenics*, 1993, vol.33, No 8, p.828-832.
- [7] Filippov Yu.P., Kovrizhnykh A.M., and Romanov S.V., "Void fraction sensor for two-phase superfluid helium flow", *Proc. of the ICEC 18*, India, Bombay, 2000, p.631-634.
- [8] Filippov Yu.P. and Alexeyev A.I. "Improvement of radio frequency void fraction sensors", *Advances in Cryogenic Engineering*, Vol.39, 1994, Plenum Press, New York, p.1097-1104.
- [9] P. Schnizer: "Magnetic Measurement Systems for the Future Project" Internal Note, GSI, October 2003
- [10] A. Jain, "Harmonic Coils", *Proceedings of the CERN Accelerator School*, 11- 17 April, 1997, Anacapri, Italy
- [11] P. Schnizer, "Experience from measuring the LHC Quadrupole axes", *Proceedings of the 8th International Workshop on Accelerator Alignment (IWAA 2004)*, October 4-7 2004, CERN, Geneva Switzerland